

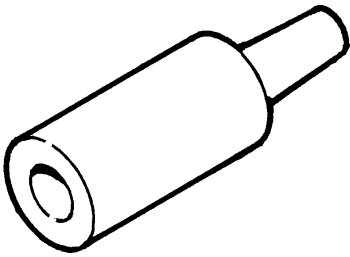

**UNITurn & UNIMill**  
*The cool tool*



## TAILSTOCK SPINDLE EXTENDER

P/N 1220

A miniature Lathe by its nature and design must fit the most function into the smallest space. This means that to turn an 8" long part on a lathe only 15" long, the tailstock cannot have too much overhang over the table. The Tailstock Spindle Extender provides this overhang while retaining the stability of the Tailstock Spindle by not requiring that it be cranked out to its maximum extension to reach out over the table.

Certain setups are made much easier by using the Tailstock Spindle Extender because it adds 1-1/2" to the reach of the Tailstock Spindle.

By using the extender, a part being held between centers can be turned from end to end without having to move the toolpost from one position to another to keep the Crossslide Saddle from hitting the tailstock. Figure 1 below illustrates how a piece of tubing held in a 3-Jaw Chuck and a Live Center can be turned from end to end with one tool post position.

You will no doubt find other occasions as well where this simple tool pays for itself many times over in convenience.

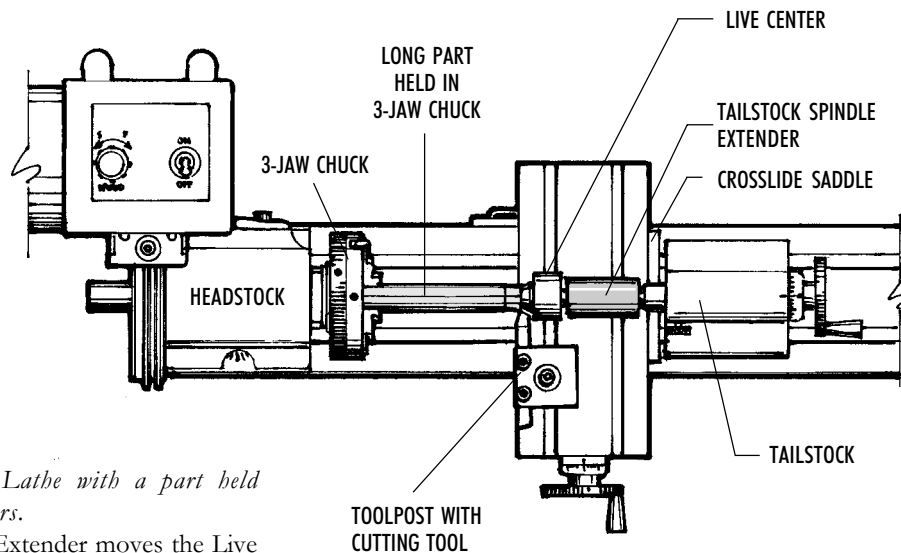

Figure 1  
Top view of Lathe with a part held between centers.

The Spindle Extender moves the Live Center out an extra 1.5" so the saddle won't hit the Tailstock when machining from one end of the part to the other in a single setup.

**The cool tool**<sup>®</sup>  
**TOOL**  
[www.thecooltool.com](http://www.thecooltool.com)

Modellbauwerkzeug & Präzisionsmaschinen G.m.b.H.  
Modelmaking & Precision Tools Ltd. Vienna / Austria  
Fabriksgasse 15, A-2340 Mödling info@thecooltool.com  
phone: +43-2236-892 666 fax: +43-2236-892666-18