



STEP-FOUR Milling Software Version 4

The brand-new Version 4 of the successful milling software used all over the world has incorporated customer ideas and requirements.

New display options for milling data

For those of you who work on several layers at varying milling depths the improved overview provided by different perspectives (XY, XZ, YZ) is indispensable. In addition, the 3D view which can be rotated in any direction will make your milling part “come to life”.

Improved DXF filter with export facility

You probably know the situation.

You have built a component or several components using your CAD program and find you have to modify them slightly or even greatly when you process them on the milling machine. As you want to be quick and the STEP-FOUR software offers ideal tools for editing the milling data, the modification is of course carried out directly in the milling machine.

Previously, to ensure your milling data correspond to the construction details in the CAD system, you always had to record the modifications and later modify the construction data in the CAD system.

This is no longer necessary. In the new professional V4 milling software V4 you simply export the milling files as a DXF file, saving a lot of time and avoiding errors.

Furthermore, the improved DXF filter also reads in new DXF formats perfectly.

A new range of options for generating milling contours

With the **Generate isolation contour** function, for instance, you can produce a completely closed milling path around a single line.

The **Contour offset** function enables you to round up or round down very precisely in addition to the milling radius.

By combining **Isolation contour** and **Contour offset** it is very easy to manufacture parts with a constant wall thickness.

If you have ever produced aluminium front panels or other optically demanding parts, you will appreciate the benefits of the **tangential** or **arc-shaped run-ins/outs**.

Another great advantage for professional manufacturing is provided by **smoothing measurements** obtained during special **smoothing cycles**.

Extended milling depth settings for processing cycles

In some cases it is useful to be able to set individual morticing depths (e.g. when processing composite materials or materials that feature considerable fluctuations in thickness). For this reason it is now possible to set the morticing depth for the **first** and **last** cycle individually. As for the **intermediate cycles**, the required **number of cycles** is simply indicated and the software automatically calculates the required morticing values.

New professional features for reaming and milling cambered shapes

Complex cambered shapes can now be dealt with by means of contour-parallel reaming as well as uni-directional reaming. A completely novel computer algorithm ensures that the correct reaming paths are achieved for complex contours that include islands and tight corners.

The contour-parallel reaming function also benefits 3D processing. You simply click on the contour-parallel reaming paths with the mouse to turn them into objects that can be converted into a layered model with the automatic layer distribution feature, after which they are milled. As a result, it is very easy to create pyramids and conical objects or even slanting shapes for moulds.

Extension module 3 for real 3D milling

Basically this is an updated Beta version of the 3D milling software. The software has been completely integrated into the normal surface, so that the operator can work in 2D, 2 ½ D and 3D without having to exit the program.

The functions were described some time ago in the Cool Tool News. If you do not have the issues concerned, please look on the Internet under the heading "3D Processing Methods" in the "Archive" section on our website www.thecooltool.com. Here are the main points:

- Real 3D path control using 3D vector analysis (look ahead)
- Import of 3D DXF files
- Import of CNC programs from 3D CAM systems (G-code subset)
- Extension of 2D and 3D object manipulation

Aids and tools

The set of tools in the STEP-FOUR software are extremely useful.

Some of the new aids include:

- Event control during the processing cycle by means of an external control signal
- Activation of an automatic tool change system
- New facility for selecting various points in order to continue an interrupted milling procedure
- Object continuity check to detect contour errors
- Deletion of double elements
- Alignment of object coordinates to step resolution

A demo version can be downloaded from our website www.thecooltool.com under the heading „Downloads“. Prices can be obtained from Cool Tool or from your local Cool Tool dealer.

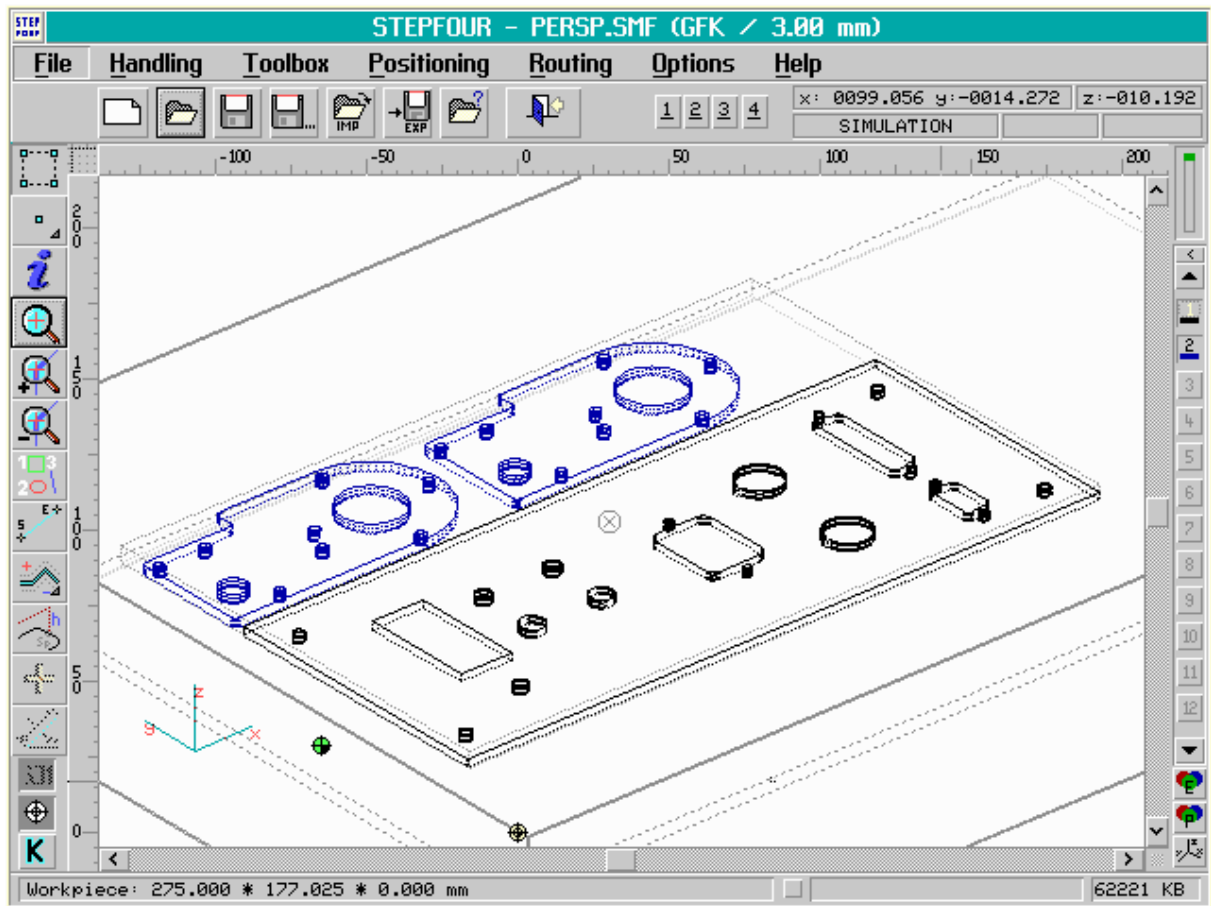

Figure 1 3D view of a milling file.

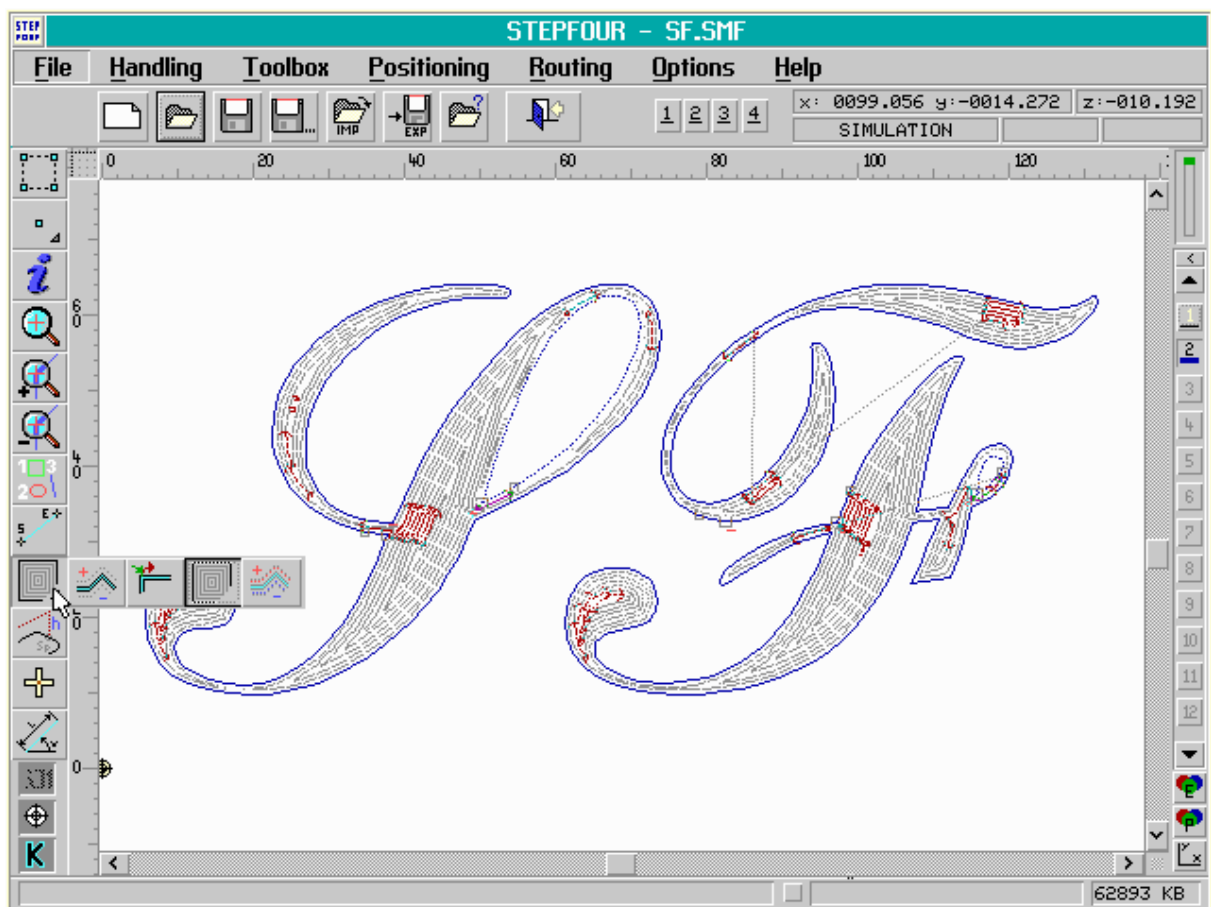

Figure 2 The contour-parallel reaming function

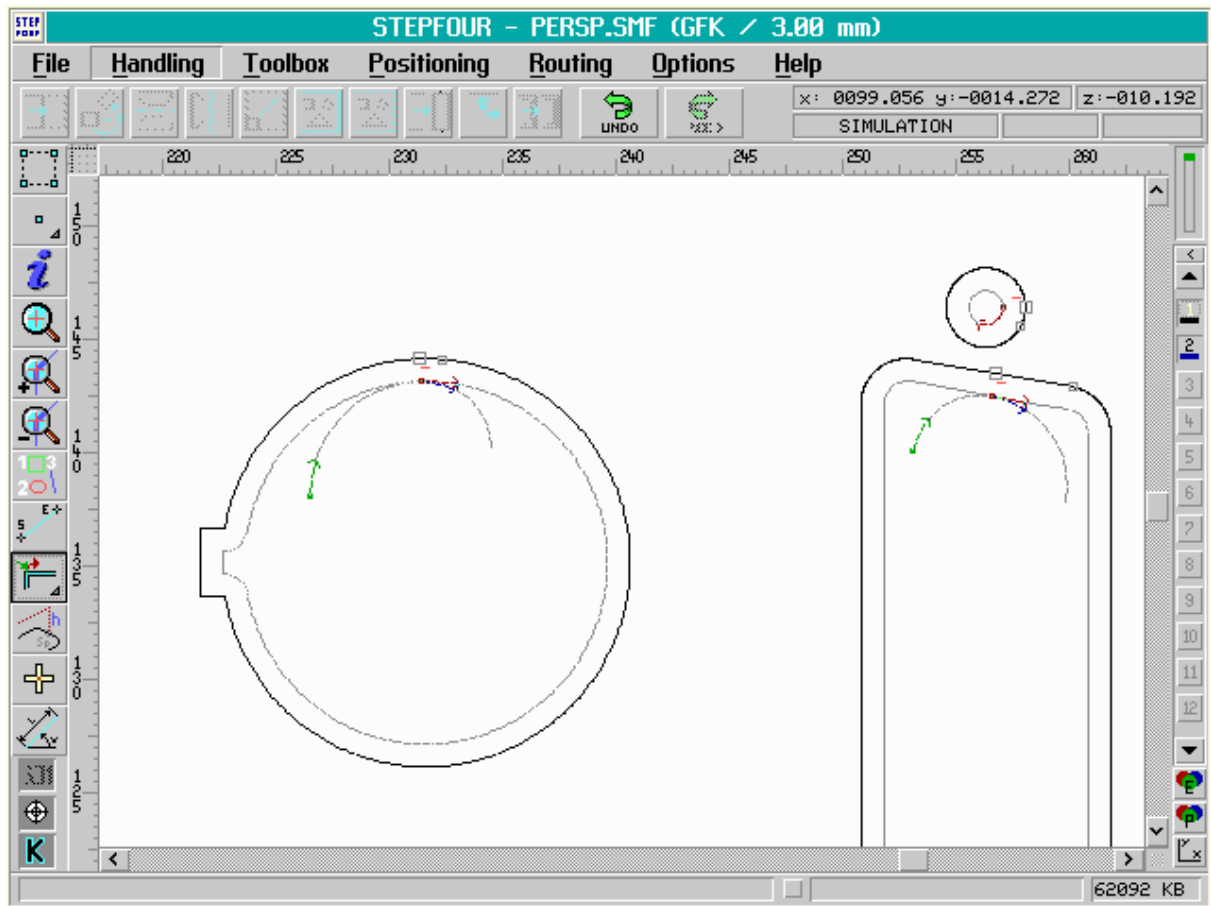

Figure 3 Front panel cut-outs by means of arc-shaped run-ins/runs

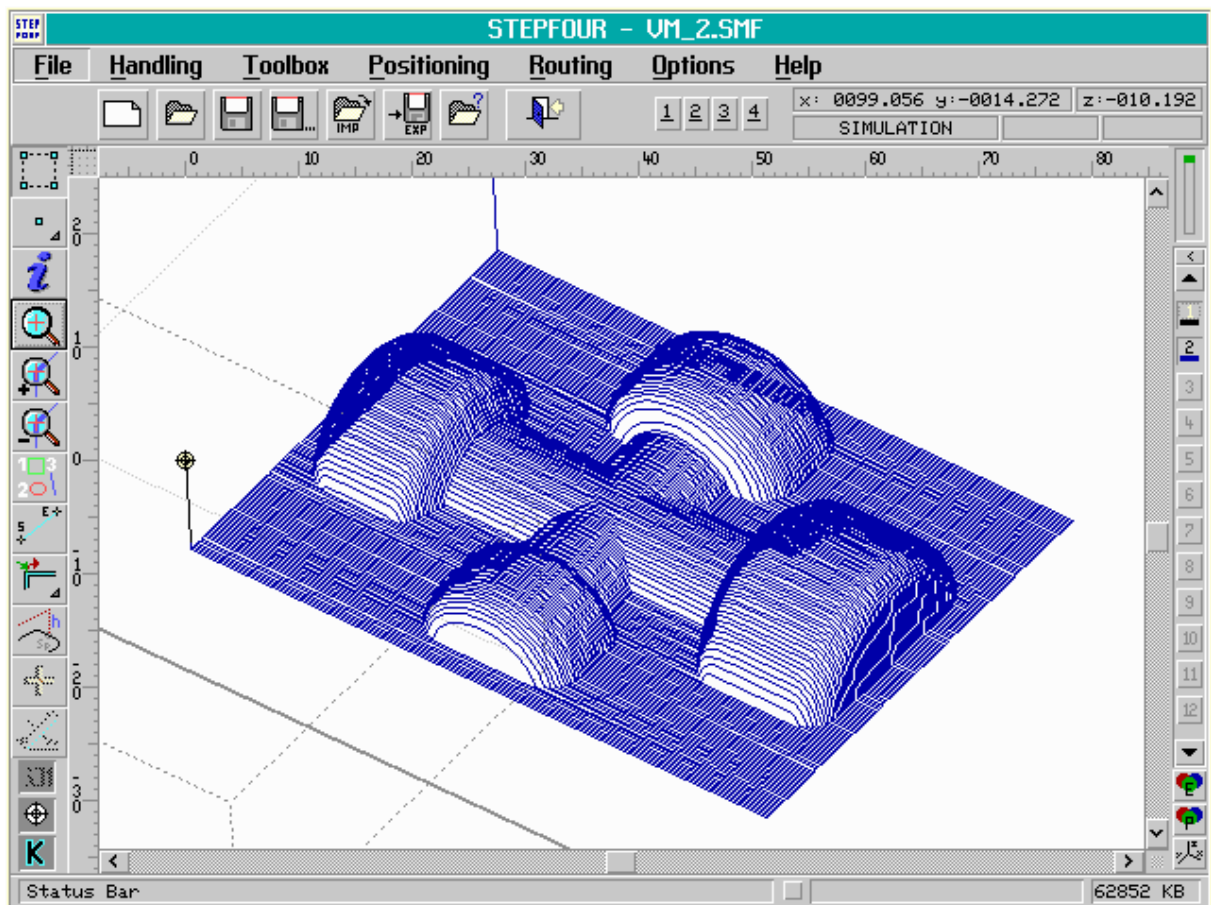

Figure 4 3D view of the milling data of a 3D object

Functions of the STEP-FOUR milling software: version 4.0

New functions in V4 are in bold italics.

File functions:

	Light	Professional
File selection with graphic preview	•	•
File selection with display of text information	•	•
Store milling file with additional data	•	•
HPGL import	•	•
DXF import (<i>improved filter for reading DXF files until Acad 2000</i>)	•	•
SMF import	•	•
SFH import (milling files from version 1.6)	•	•
Import of several files		•
HPGL export of milling files		•
<i>DXF export of milling files</i>		•

Handling:

Manual rotation and moving of entire file	•	•
Manual zoom out and in of entire file	•	•
Separate geometric data into single objects		•
Group objects and subgroups		•
Move objects and groups		•
Rotate objects and groups		•
Mirror objects and groups		•
Scale objects and groups		•
Duplicate objects and groups		•
Align objects and groups to each other		•
Convert corrected milling paths into single objects		•

Milling functions:

Tool data base	•	•
Material data base	•	•
Automatic tool radius compensation for inner/outer contour	•	•
Define objects as drilled holes	•	•
Mill drilled holes if diameter > router diameter		•
<i>Generate isolation contour</i>	•	•
<i>Generate a contour offset in addition to milling radius</i>	•	•
<i>Define tangential or arc-shaped run-ins/outs</i>		•
<i>Mill over starting point</i>		•
Automatic and manual setting of milling direction	•	•
Automatic and manual definition of milling sequence	•	•
Administration of 256 milling layers	•	•
Free setting of advance feed, spindle speed, morticing cycles, etc. per milling layer	•	•
<i>Separate depth settings for first, last and intermediate cycles</i>	•	•
Activation of two outputs for ventilation, suction, etc.		•
<i>Event control during processing cycle by external signal</i>		•
Advance calculation of milling time		•

Basic settings / manual operation:

Connection of reference and end switches		•
Manual definition of reference point	•	•
Automatic reference travel		•
Definition of workpiece coordinate system	•	•
Definition of material zero point	•	•
Manual operation by way of keyboard and coordinate input	•	•
<i>Travel to certain positions defined by clicking with mouse</i>	•	•

Automatic milling operation:

Simulation mode on screen	•	•
Mill all	•	•
Interrupt milling operation	•	•
Continue from interruption point	•	•
Select various points to continue milling procedure		•
Mill selected objects and groups		•
Mill single objects		•
Mill from a certain object to end		•

Screen display

Simulation mode with actual tool diameter	•	•
Zoom in on milling area	•	•
Zoom in on selected objects	•	•
Manual zoom	•	•
Display various XY, XZ, YZ and perspective views	•	•

General functions

Unlimited "Undo" and "Redo" steps for most commands	•	•
Options to adapt mechanical and electrical drive parameters	•	•
Adjustable curve to adapt various milling spindle	•	•
Measurement function to check distances between milling objects		•
Context-related help system for all functions	•	•

Extension modules for V4.0 STEP-FOUR professional milling software

(can only be used with the professional version)

Drawing and object manipulation module		
Insert and delete points		•
Link and separate objects		•
Multi-dot edit		•
Align objects to line		•
Generate point, line, polyline		•
Generate circle, ellipse, N corner		•
Generate square, rectangle		•
Bevel corners		•
Round corners with/without drilled hole in centre		•
Cut objects		•
Melt objects		•
Reduce object points		•
<i>Check object continuity</i>		•
Align object coordinates to step resolution		•
Delete double elements		•

Reaming and layer distribution model		
Assign reaming parameters to an object or group of objects		•
Contour-parallel or direction-parallel reaming		•
Recognition of islands in objects on same or higher milling layer		•
Removal of residue also for intricate interlocking islands		•
Automatic layer distribution for layered line models		•
Automatic generation of reaming cycles for layered models		•
Definition of a smoothing cycle with corresp. compensation to object contour		•

3D-NC control module		
Import of 3D-DXF files		•
Import of CNC programs from 3D-CAM systems (G-code subset)		•
Real 3D path control via 3D vector analysis (look ahead)		•
Extension of 2D object manipulation to 3D object manipulation		•

A software protection switch is required to prepare data on another computer than the one used to control the milling system.

The V4 **STEP-FOUR** milling software can be used to control external systems and electronic units with the dongle or interface provided, depending on the range of functions required.

- The update of V3 LT to V3 professional version is still available.
- The extension modules for the V3 professional version are also still available.
- An update of V3 professional version to V4 professional version is **ONLY** possible if existing extension modules are updated at the same time.



**Modellbauwerkzeug & Präzisionsmaschinen G.m.b.H.
Modelmaking & Precision Tools Ltd. Vienna / Austria
Fabriksgasse 15, A-2340 Mödling info@thecooltool.com
phone: +43-2236-892 666 fax: +43-2236-892666-18**