

UNIMAT 1

BAUVORSCHLAG
BUILDING PROPOSITION

FEDERELEMENT
SPRING-ELEMENT



The **cool**®
tool

www.thecooltool.com



Modellbauwerkzeuge & Präzisionsmaschinen G.m.b.H.

Modelmaking & Precision Tools Ltd. Vienna/Austria

Fabriksgasse 15 A-2340 Múdling info@thecooltool.com

Phone: +43-2236-892666 fax: +43-2236-892666-18

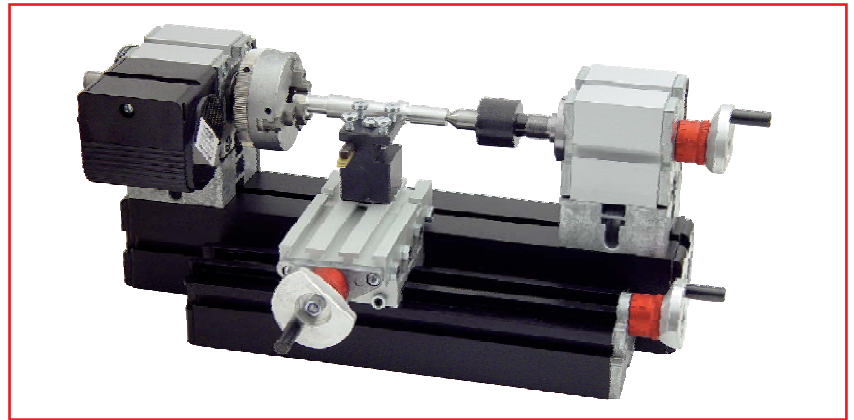

FEDERELEMENT SPRING-ELEMENT

-  Aufbau der Drehmaschine
-  Construction of the lathe



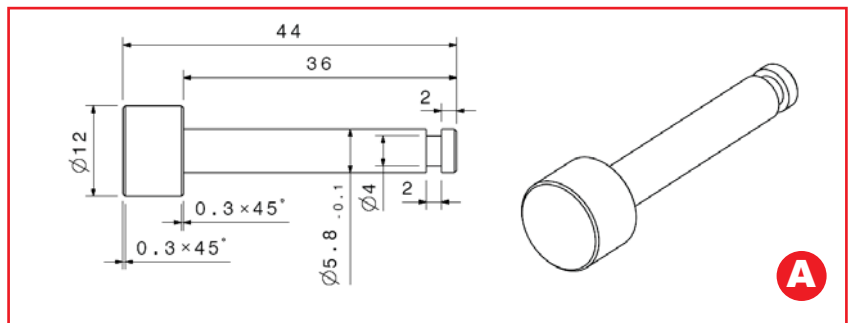



-  Federbolzen
-  Springbolt

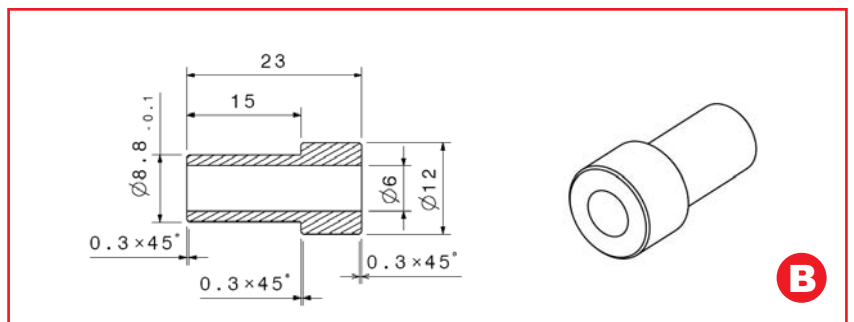



-  Federführung
-  Springguide



-  Zusammenbau der Teile
-  Assembly of the parts

-  Druckfeder 1,0 x 11 x 26 mm
-  Spring 1,0 x 11 x 26mm

-  Sicherungsscheibe DIN 6799-4
-  Retaining ring DIN 6799-4

